

# DEMETER PROJECT

## USING CAD UNIT



## **UNIT 2 : Using CAD.**

This unit will allow students to learn and understand how to use CAD on a project, through using CAD software like Solidworks.

The first step will be to begin with the use of essential CAD function (visualization...). Students have to master those functions to be able to do this unit.

In the second part, they will learn how to create (or modify) a new CAD part.

The new CAD part can be 3D print, which allows students to see the result of their work.

The last part of the unit will be the CAD assembly rover. The students work on the whole assembly (confirmed level) or just on little subassembly (beginner level).

This step might be the introduction of the real rover assembly, students can see the assembly order, the different mechanical links...

## **Teachers**

This unit was carried out by the Mechanical construction teacher.

## Duration

This Unit consists of 3 lessons.

## Objectives and Key competences

Mechanical construction :

- space vision and sketch mastering
- CAD use.

## Material / resources

- Pc with CAD software.
- The real rover

## Lesson 1 : How to begin with CAD on a project?

How to use the different functions to visualize a CAD model?

It allows to hide, show some parts, cut, zoom in order to see details and other basic functions.

CAD also allows to see hidden details on the real object, here, the rover.

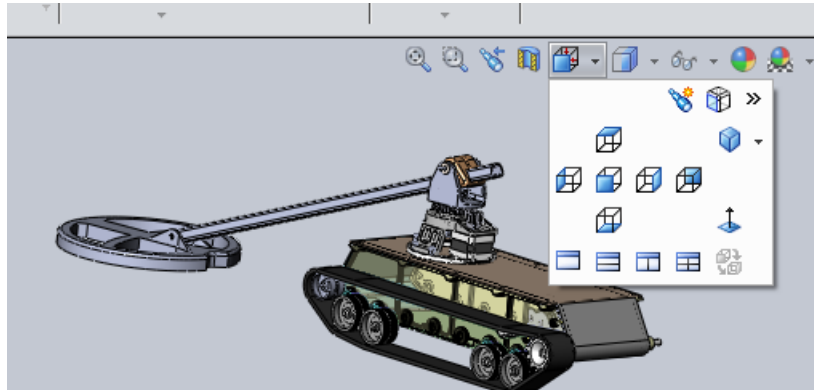

**First step :** Turn the view of the model and zoom using the mouse.

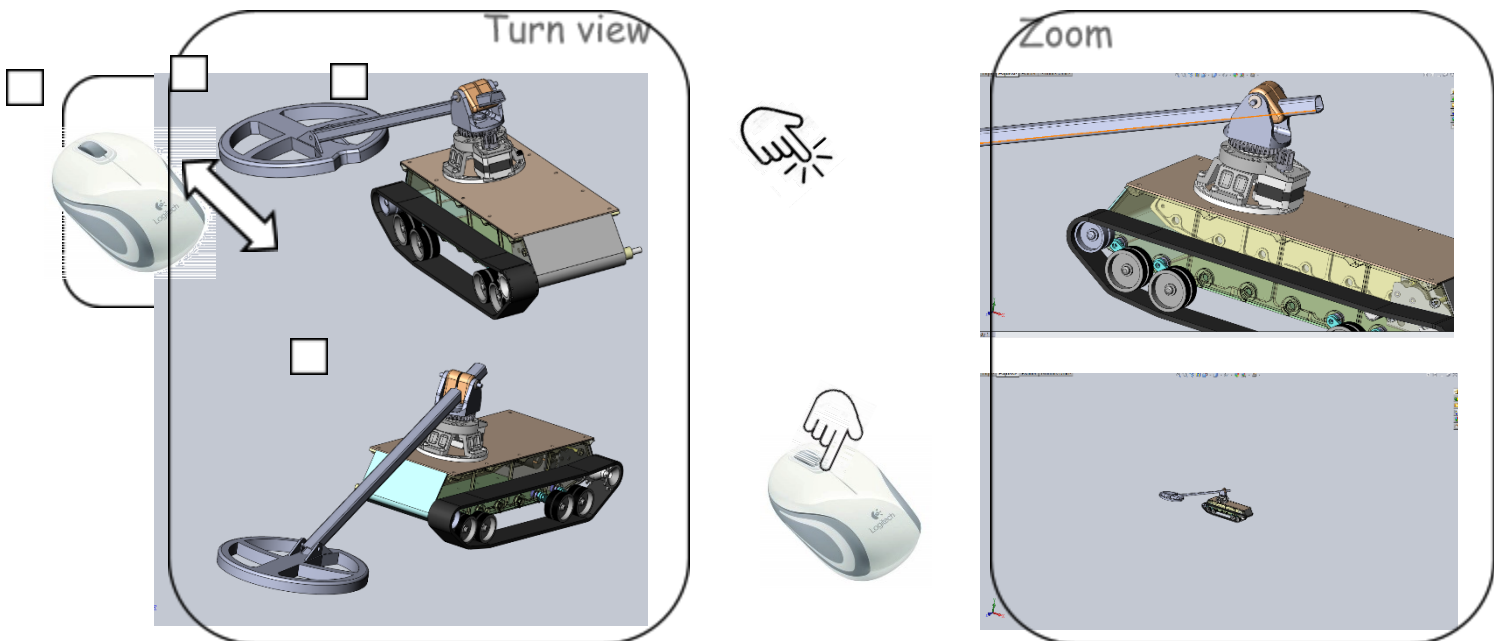

**second step** : students visualize the rover from the different views (front, left side, top view...). They have to find details on each view. For example, on the front view, they have to count how many wheels there are. A paper or a digital document may be completed for each icon.

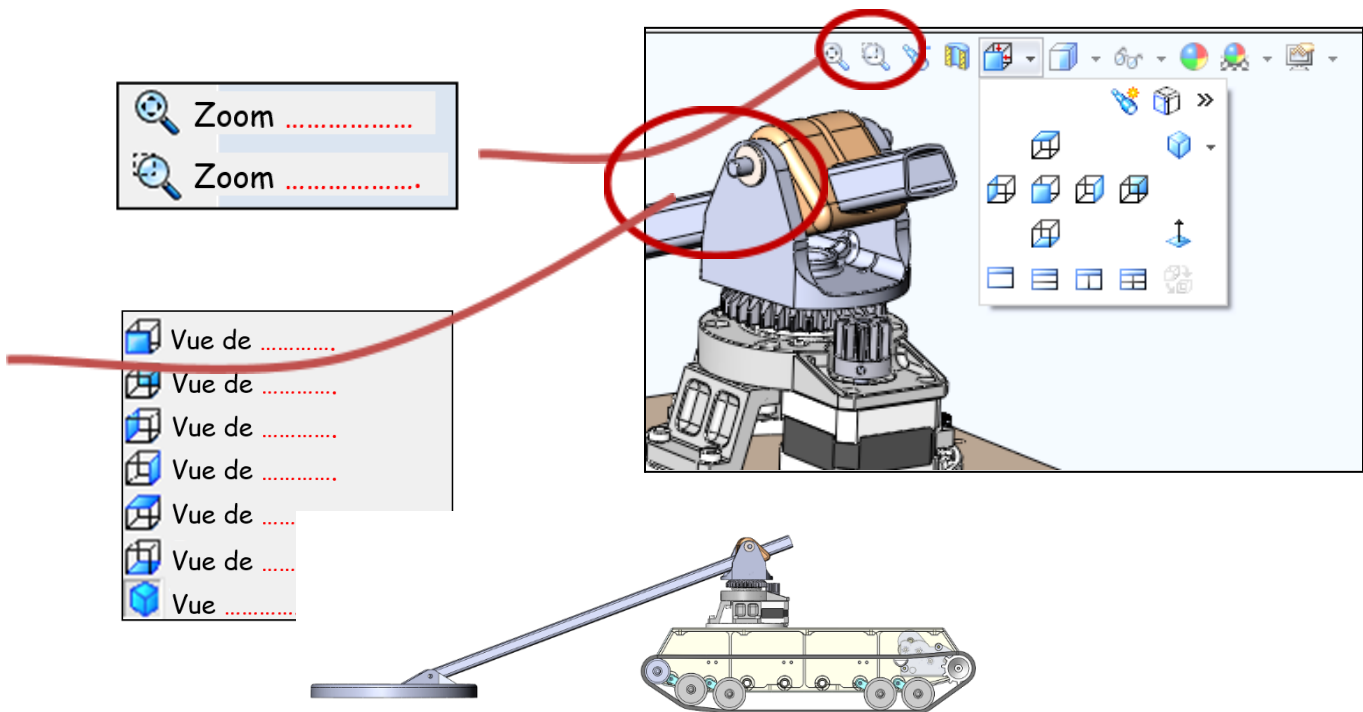

Students try to click on most important icons to obtain different views

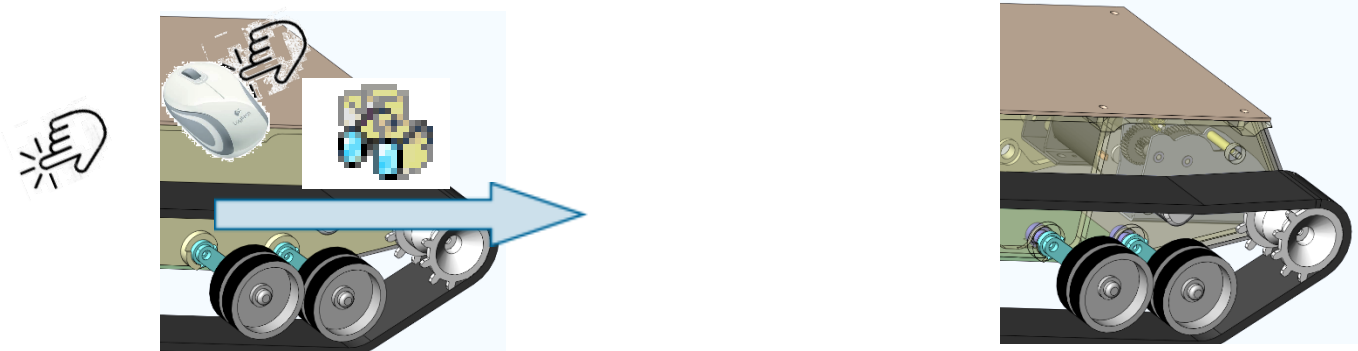

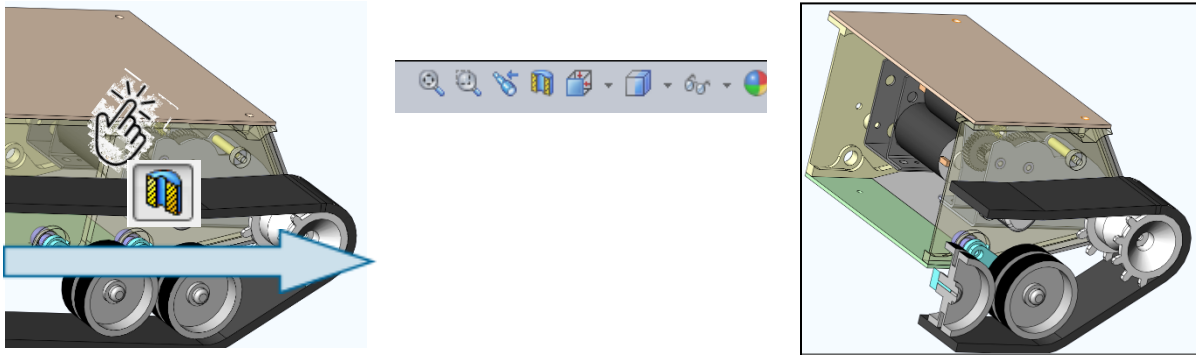

**Third step** : students visualize the different parts of the rover. They can identify the name of each part and their location. The link between parts list and picture is highlighted.

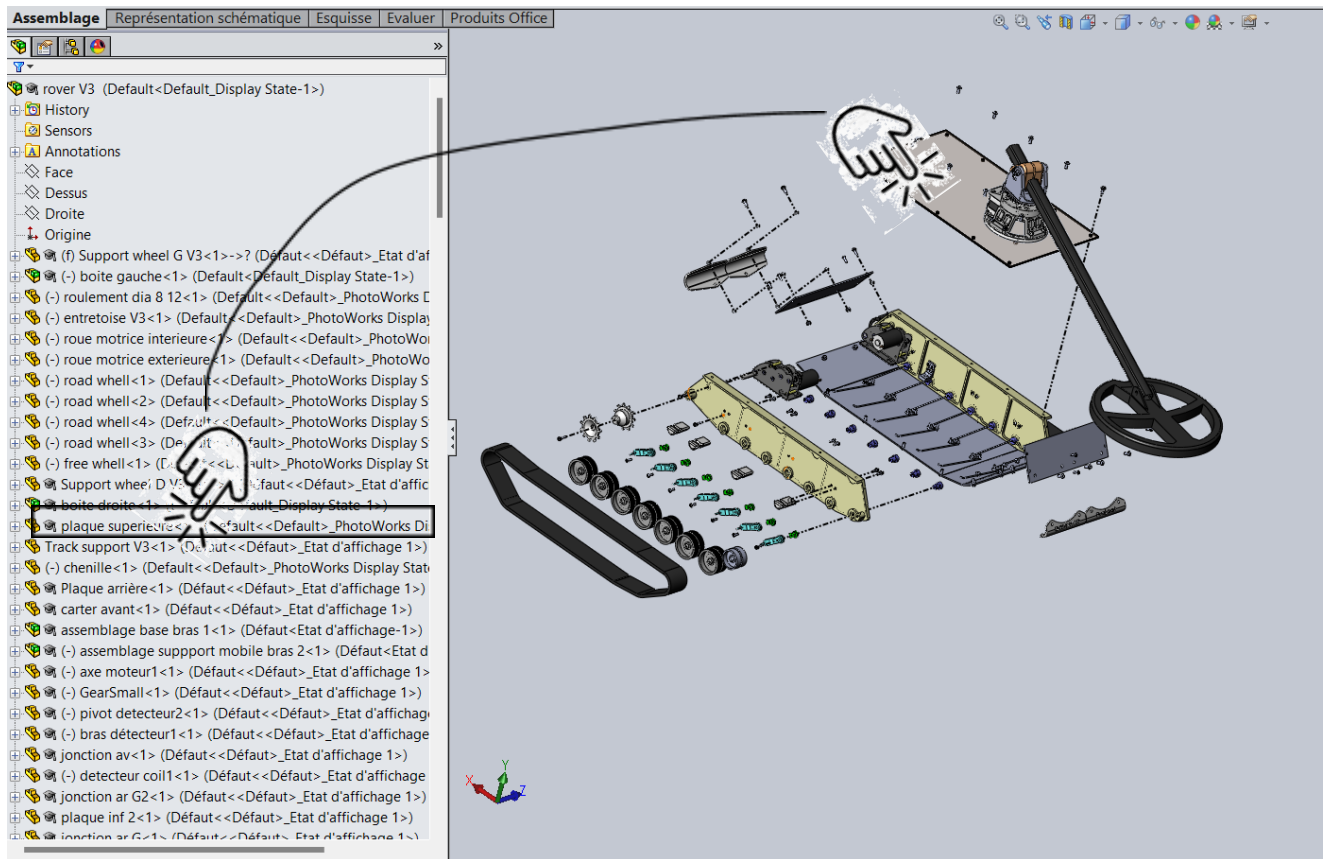

**Fourth step** : students open the model of one part of the rover. They are able to visualize, modify, measure... this part.

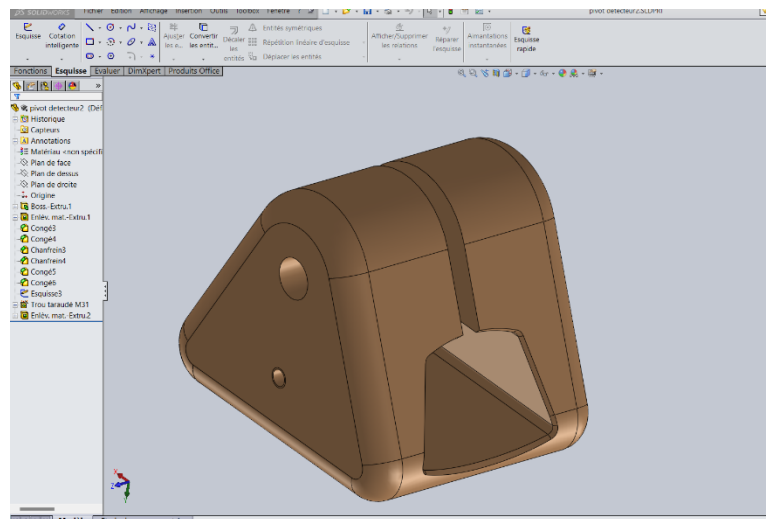
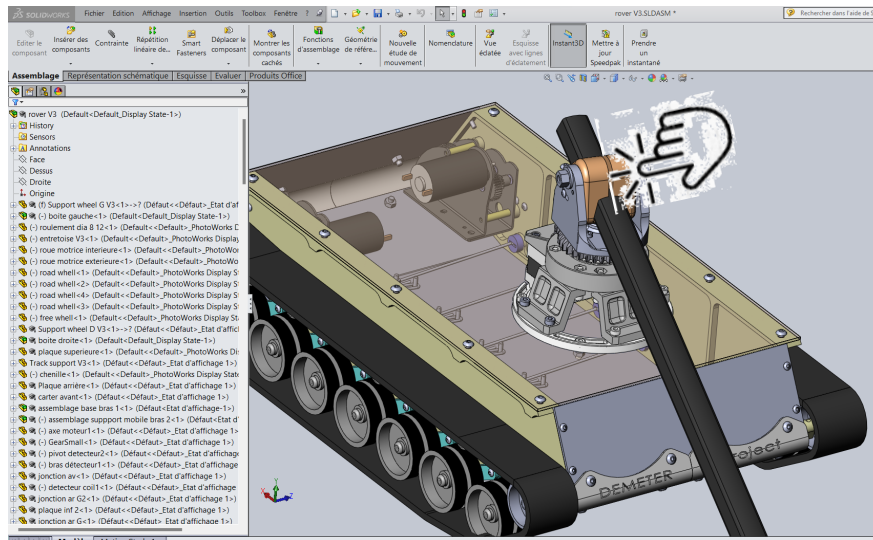

**In conclusion :**

This activity allows students to discover CAD possibilities through the project. The real rover can also be used to compare dimensions, shape...

## Lesson 2 : How to create (or modify) a part with CAD on a project?

The project is the best support for students to understand the need of CAD. It provides a final part to be modified easily. It's also a device which allows 3D printing and machining.

Moreover, the user can see a real part after conception step.

The part might be created in an assembly or outside the assembly. This lesson is only about the creation outside the assembly. The creation inside an assembly needs more previous skills

Whatever the CAD software used, the principle of creation is nearly still the same.

**First step** : The dimensions and shape of the new part comes from the environment. The dimensions and shape might be taken from the assembly, from another part, or from a real part...

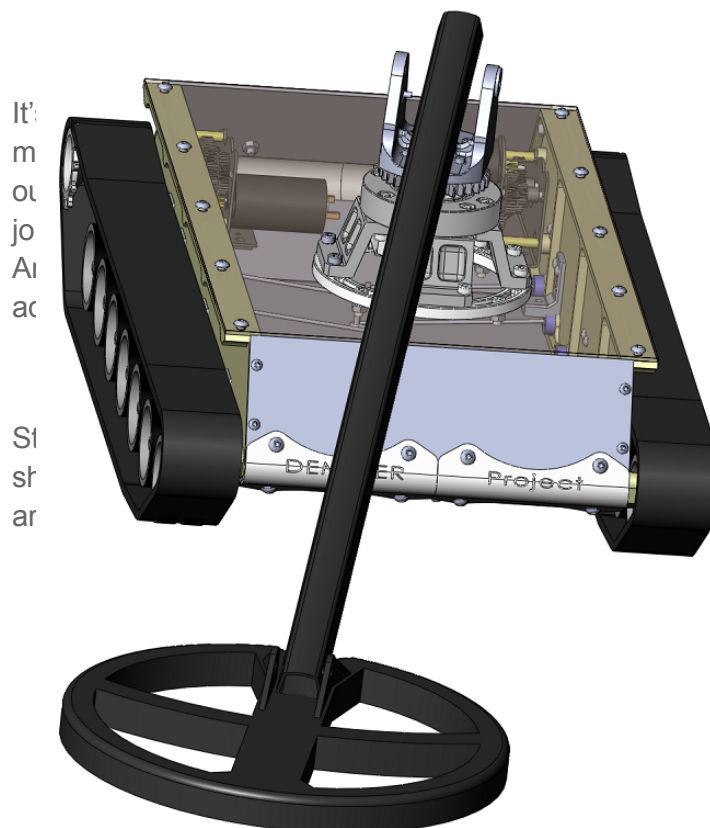



**Second step** : Find the dimension and shape of the main surface part. The main surface of the new part is the arm support surface.

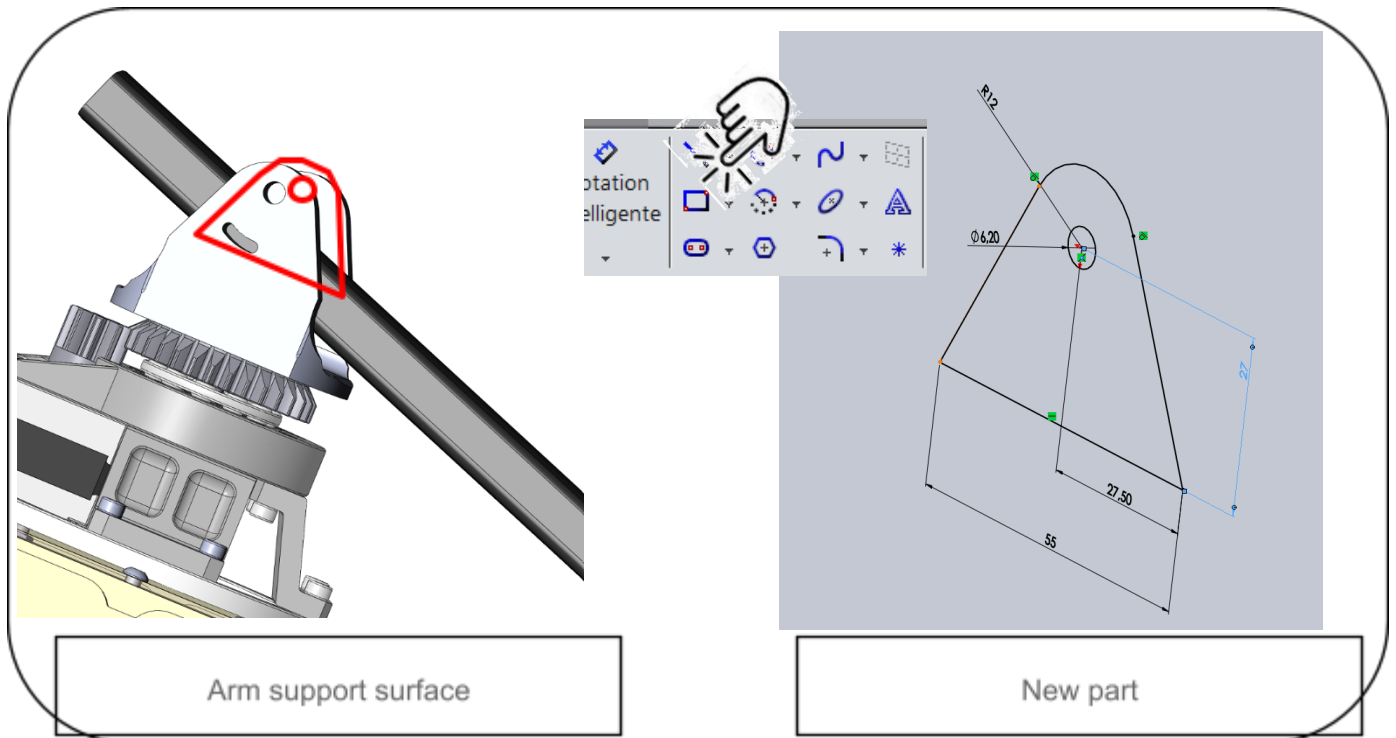

This first sketch must be completed with all the functional dimensions. Of course, the dimensions might be changed all along the creation.

**Third step** : add volume to the sketch. The dimension might be taken on the real part or on CAD model.



**Fourth step** : Find and add dimensions from the detector to the new design part. Students have to visualize the model in 3 dimensions to transfer the dimensions on the good plane. The real part of the detector helps students to do that.

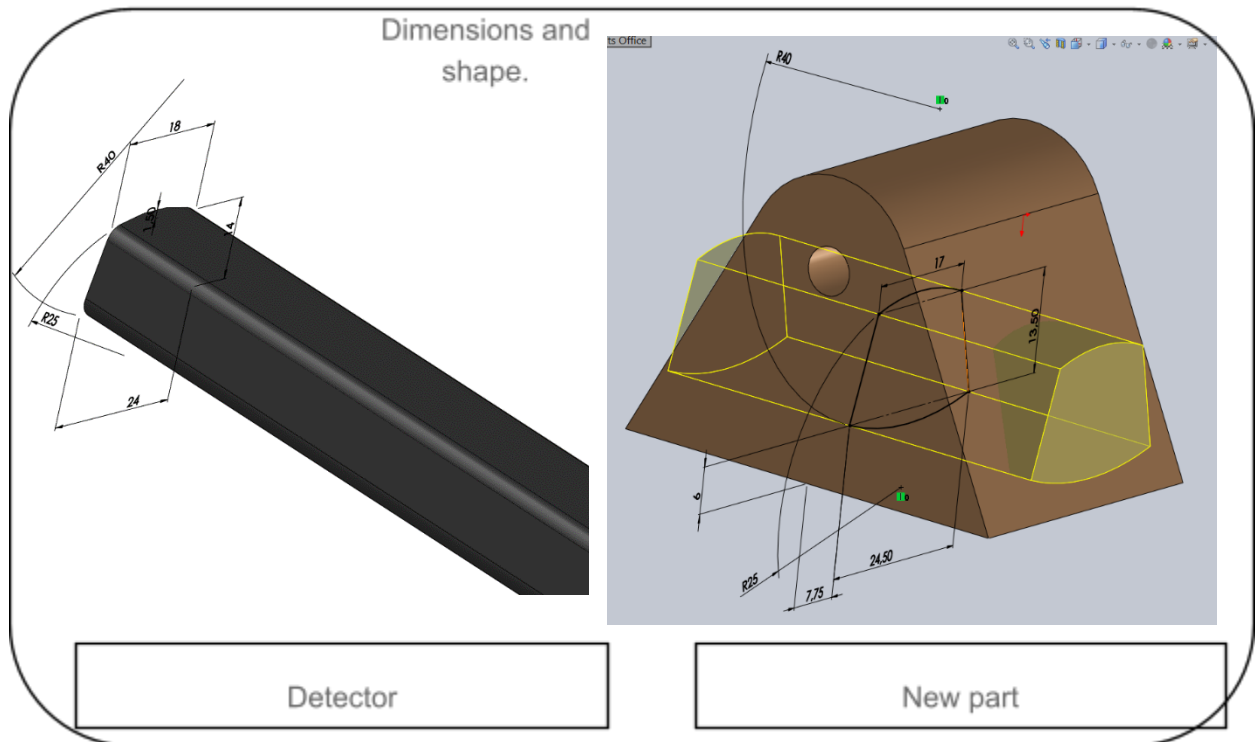

**Fifth step** : Add the technical function : adjusting the detector position. A drilling thread is added to adjust the detector position on the arm support. A slot must also be added to tighten the detector in position. There are many solutions to solve this technical function, students have to find one. The 3d print allows to try easily if the chosen solution is compliant.

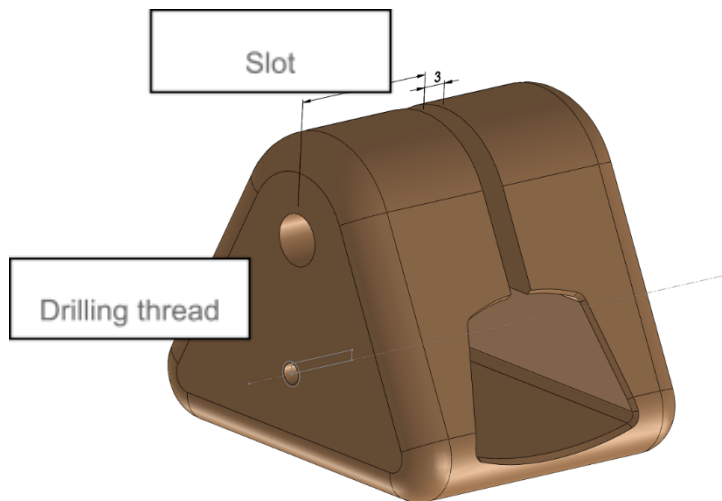

**Conclusion** : The new part has to be inserted in the CAD assembly (lesson 3) to check the reliability. Before printing in 3D, students can visually check, if there is no problem with the environment parts. They can also try the motion detector on CAD.

### Lesson 3 : How to assemble the rover model parts on CAD?

Most of the rover CAD parts have now been designed, the last step is to make a CAD assembly in order to check if there are interferences and to draft a technical documentation to help for the real assembly.

This lesson introduces technical surfaces for studying mechanical links.

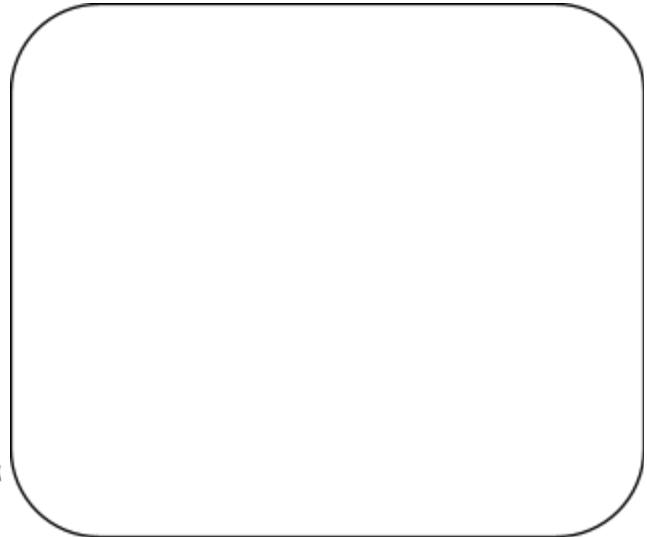

**First step :** The CAD function which allows to assemble 2 parts is based on selection of contact surfaces between the 2 parts to be assemble.

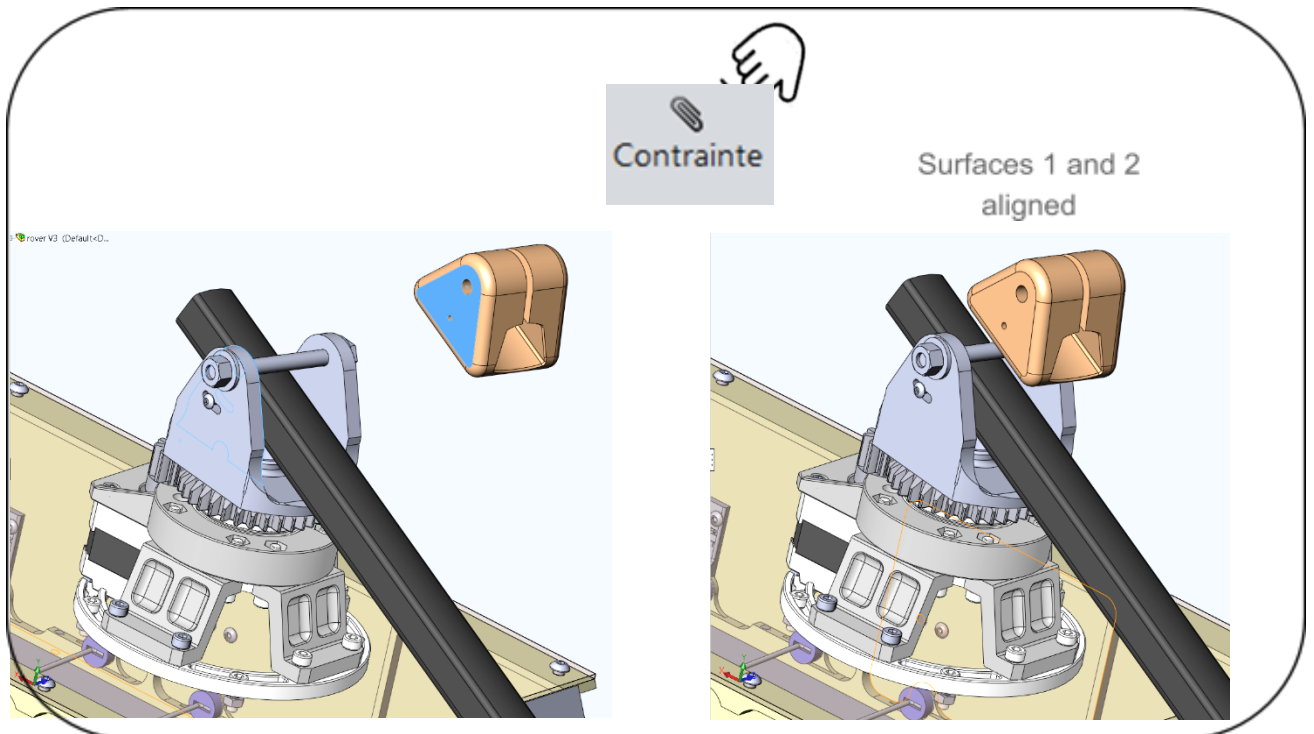

Same operation for the axis of the support and the axis of the pivot :

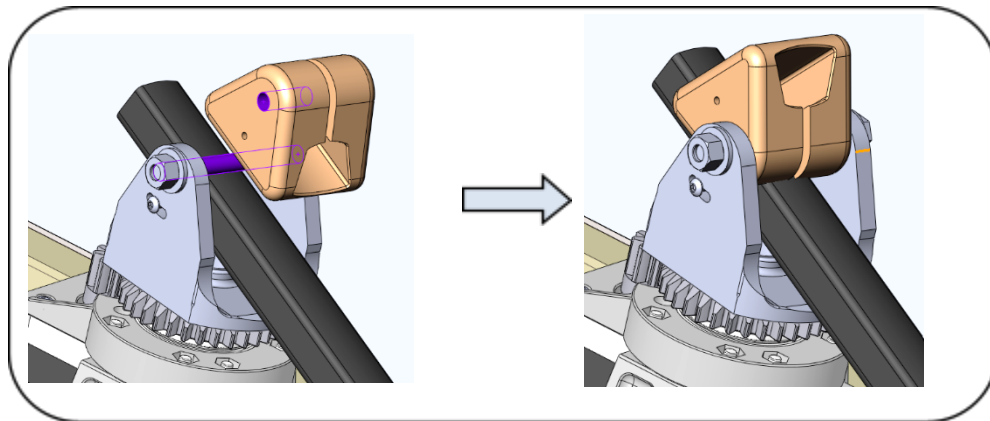

**Second step** : The pivot is now link to the support arm although it can move. The pivot will be completely located in the assembly when the link between the pivot and the detector will be done.

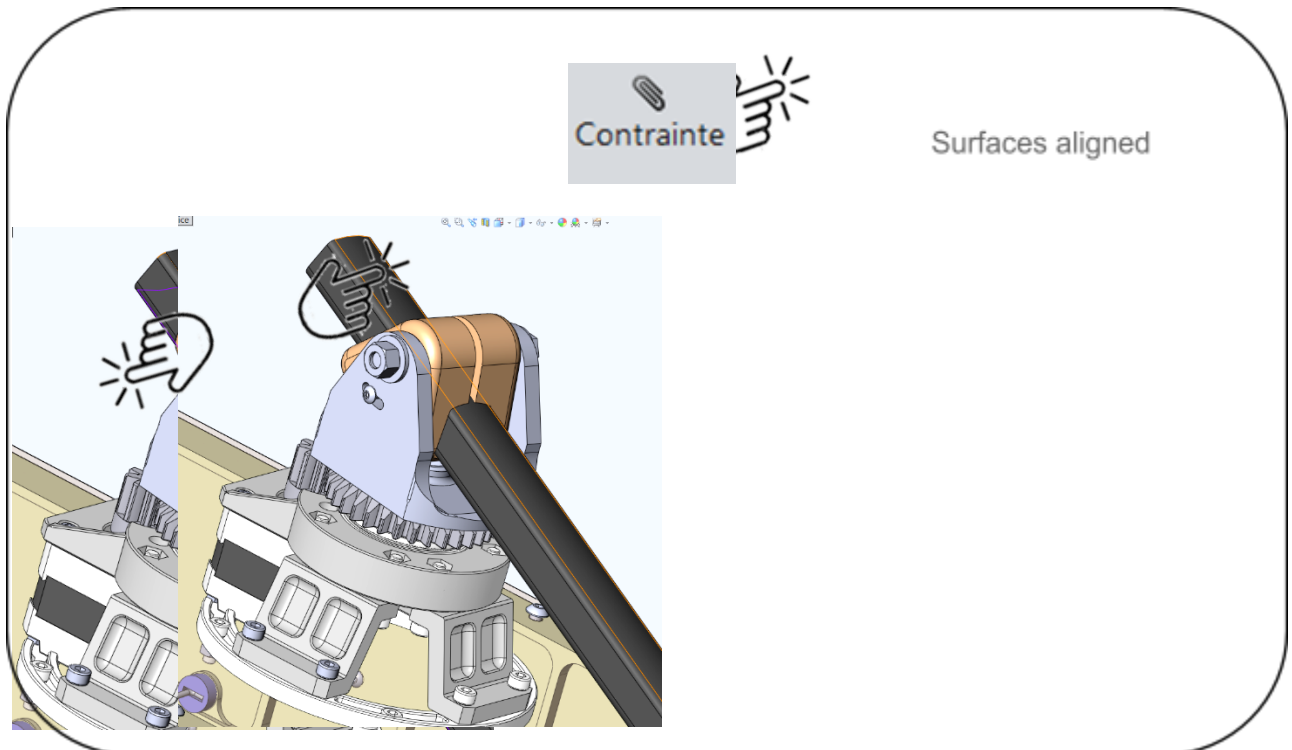

**Last step** : The last link is between the adjusting screw and the pivot. Some other links can be added, for example, the distance between the end of the detector and the pivot...

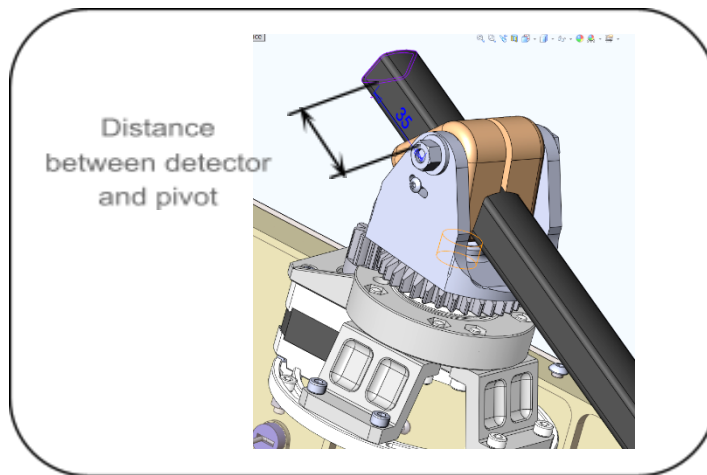

**Conclusion** : The whole CAD assembly might take a lot of time but it can be divided easily by subassembly (the arm, the chassis, motorization...). In function of students skill level, this CAD assembly can be used by beginner to confirmed students.

## Results and outputs

- The students were able to use CAD software. The CAD final assembly is the output result.
- They also can use 3D printing to check results.

## Teachers' evaluation of the lessons

Students are involved on CAD using because the project allows students to see assembly progress.

This unit is motivating for students because they can quickly see the evolution of the part. The result allows to link the detector on the arm and to print the real part which are important steps of the project. The motorization of the arm was made by the Spanish team and the conception by the French team, students involved on this project were motivated to transmit their work and see the project goes on.

This activity is very interesting for students because it used very simple CAD functions and they see the CAD rover assembly advancing very quickly. Moreover, it's a good preparation for the real assembly.